

Description

Our Ceramic Heater offers a unique technical design and high durability. It comes with or without fins (which of course can be customized). The fact that the flat pins are integrated takes away the risk of damage. This, so called, sandwich element can either be inserted or mounted with fixations (the latter for class 2). The Ceramic Heater is light weight with an aesthetic finish and high inertia.

Technical specification

Material	Ceramic / Thermotte	
Standard dimension	406 x 215 x 30	1000W
	566 x 215 x 30	1250W
	609 x 215 x 30	1500W
	Other dimensions on request	
Fixing device	Class 2 plastic fixations	
Connection	Integrated flat pins	
Design	With or without fins	
Power	On request	
Voltage	230 V or others on request	
Safety	The element meets requirements acc. to EN 0335-1	

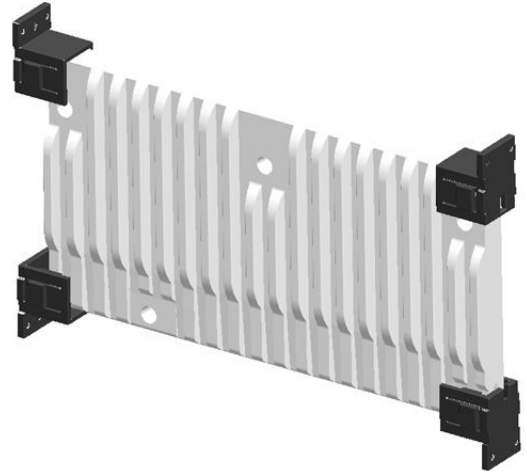

Tubular Elements

BENEFITS

- Accumulated effect /high inertia
- Even heat distribution
- Soft heat
- Light weight
- High durability
- No risk of leakage
- Aesthetic finish

FIELDS OF APPLICATION

- Dry radiators



Towel dryer