

# BACKER IMMERSION HEATERS FOR HYDRAULIC OIL HEATING WITH ELEMENT TUBES IN ACIDPROOF STAINLESS STEEL

BACKER

## Properties

Backer standard range of screw plug immersion/insertion heaters in stock are suitable as heat sources for instance in tanks, tubes, industrial baths and some applications at forced or stationary air heating.

The heaters consists of 3 pieces Backer tubular heating elements soldered to a screw plug. It could be fitted with different accessories such as terminal box, thermostat, safety temperature limiter, tube and insulation for flow-through heater, socket key for assembly, etc.

## Technical specification

Material	Tubular elements Ø8,5 mm in acidproof stainless steel EN 1.4404/AISI 316L Screw plug G2" (R50, 60 mm) in brass Tube for thermostat/temp.limiter Ø12x0,7 length 260 mm
Inactive length	100±10 mm
Electric connection	M4
Assembly	Kit with gasket and connection parts included
Max working temperature	120°C
Max working pressure	9 bar
Manufacturing standard	Backer 40579311 CE
Standards	SS 4330701, SS-EN 60335-1, UL-1030, ISO 6469-3
Power tolerance	+5% / -10%
Surface power density	Approx 0,9 W/cm <sup>2</sup>

## Standard assortment

Type OE	Power W	Voltage V	Insertion length Max mm	Article no
OE 311	330	230/400	270	2530490205
OE 331	670	230/400	435	2530490201
OE 341	1000	230/400	555	2530490202
OE 361	1500	230/400	815	2530490203
OE 391	2000	230/400	1085	2530490204



Type OE311-331

# BACKER IMMERSION HEATERS FOR HYDRAULIC OIL HEATING WITH ELEMENT TUBES IN ACIDPROOF STAINLESS STEEL

BACKER

Type IDUK

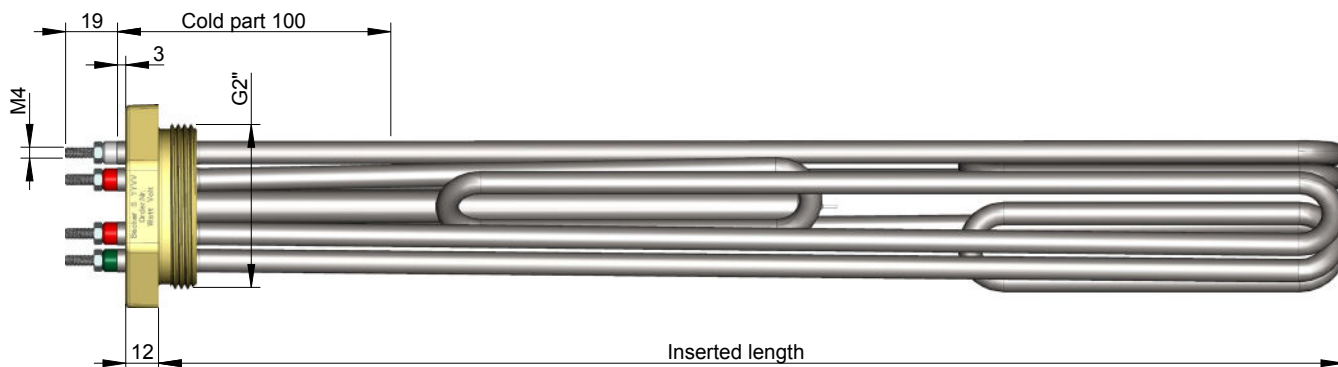

## Circuit diagram/ connection alternatives\*

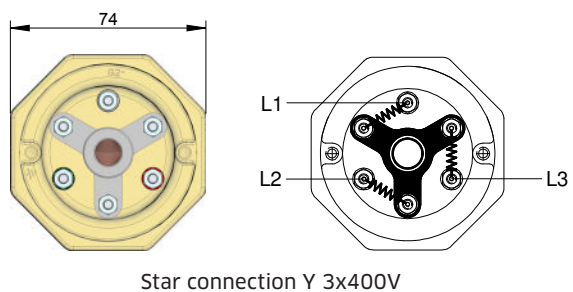

Star connection Y 3x400V

\*Electric connection must be performed by an appropriated elec-

## Option

- Terminal boxes, thermostats and safety temperature limiters, different options
- Tube and insulation for flow-through heater, different options
- Socket key G2" article no 1160143201
- Nut G2" in brass article no 1140485405