

Polaris Modular Tank Heater

Non Corrodible electric tank heater

Polaris Modular fluoropolymer immersion heaters are designed for use where aggressive chemicals need to be heated to temperatures up to 100°C, and have optimum chemical resistance against corrosion caused by chemicals

Typically for use in the metal finishing and process industries, small and compact to fit inside tanks without causing obstruction.

Use vertically or horizontally.

1.0kW to 12kW

Single or three phase



Used By

- Steel Strip Manufacturers
- Wire & Tube Manufacturers
- Metal Finishers
- Chemical Plants
- Galvanising Industry
- Aerospace Industry
- Chemical Millers

Main Features

- Will not corrode
- Easy to install
- Compact to fit behind anodes
- Integral baffles for protection
- Supplied with hanging brackets or standoffs
- Low watt density 0.7 w/cm²
- Fully flexible cable
- High thermal efficiency

BRAUDE Products will not corrode

Polaris Modular Tank Heater

Completely resistant to a wide range of chemical solutions, its low watt density and robust construction with integral protective baffles, extend lifetime and versatility in aggressive environments.

The heater is small enough to fit behind anodes and in other confined spaces. For maximum safety the Polaris Modular has a well proven earthing system in the form of a coaxial element and is just about the safest heater available. Standard Braudeflex lead length is 2m with up to 8m available to order.

Technical data

RATING	APPROX PACK WEIGHT	HEATER DIMENSIONS			VOLTAGES		LEAD LENGTHS		
		HEIGHT	WIDTH	THICKNESS	Single Phase 240V	Three Phase 415V	2.0M	3.0M	5.0M
kW	KG	MM	MM	MM					
1.0	1.3	80	266	43	✓		✓	✓	✓
1.5	1.5	120	266	43	✓		✓	✓	✓
2.0	1.6	160	266	43	✓		✓	✓	✓
3.0	2.0	240	266	43	✓	✓	✓	✓	✓
4.5	3.6	240	266	86	✓		✓	✓	✓
6.0	4.5	240	266	86	✓	✓	✓	✓	✓
9.0	6.0	360	266	86	✓	✓	✓	✓	✓
12.0	7.5	480	266	86	✓	✓	✓	✓	✓

1.5kW 3phase has same dimensions as 3kW

Add 20mm to thickness for horizontal height. Baffles fitted as standard thickness of 3mm Immersion depth, all units minimum 50mm of solution above heater height

Dimensions and details may be subject to alteration at the manufacturers discretion without prior notification.

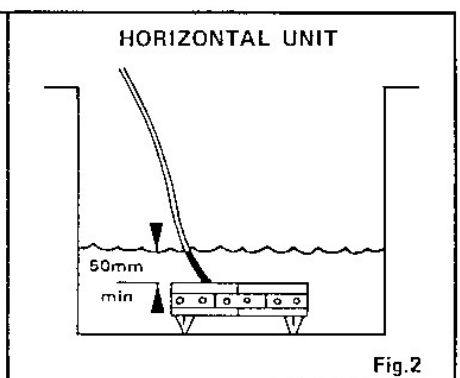
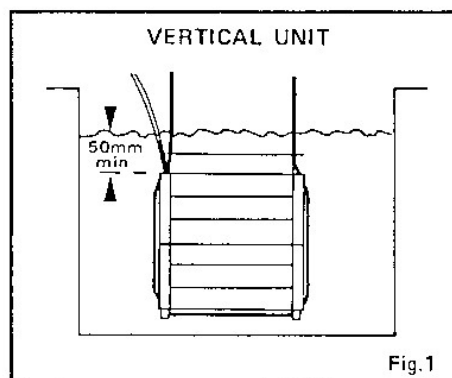

BRAUDE a trading division of
Heatrod Elements Ltd

Unit 5, Wellington Business Park,
Dukes Ride,
CROWTHORNE, Berkshire RG45 6LS.
UK

Tel: +44 (0)1252 876123

www.braude.co.uk
sales@braude.co.uk

VAT: UK628867390

Thermal Process

Equipment Specialists